



# STAX ECO MULTI

## Outdoor Floodlights



**2POWER**  
Switchable  
Modes



**TRITONE**  
Colour  
Changeable



**IP66**  
Ingress  
Protection  
Rating



**IK08**  
Impact  
Rating



**50,000hr**  
Expected  
Lifetime



**3yr**  
Warranty

### Compact and flexible.

STAX ECO MULTI is a versatile and efficient LED Floodlight. With selectable colour temperature, dual power version and optional PIR motion sensor, it is suitable for a wide range of applications.

#### Features

- Tritone colour selectable
- IP66 weather resistant housing
- Easily adjustable
- Compact design
- PIR motion sensor available
- Corner mounting options

#### Benefits

- Reduced SKUs and inventory levels
- Robust and durable
- Simple maintenance and repositioning
- Suits most applications
- Added security and safety
- Installation freedom

**Product Overview**

POWER	LUMENS	EFFICACY	CCT	DIMENSIONS	WEIGHT	SAP CODE	PRODUCT CODE
15W	1720 lm	115 lm/W	4000K	140 x 178 x 26mm	0.6kg	2002130	<b>STAX15W30W-TRI</b>
	1850 lm	123 lm/W	5000K				
	1740 lm	116 lm/W	6000K				
30W	2710 lm	90 lm/W	4000K				
	3180 lm	106 lm/W	5000K				
	2960 lm	99 lm/W	6000K				
50W	5530 lm	107 lm/W	4000K	210 x 147 x 45mm	1.2kg	2002131	<b>STAX50W-TRI</b>
	5410 lm	108 lm/W	5000K				
	4730 lm	95 lm/W	6000K				

**SPECIFICATIONS**

<b>Body Material:</b>	Aluminium	<b>Driver:</b>	Integral
<b>Diffuser Material:</b>	Glass	<b>Power Connection:</b>	15/30W: 0.6m Flex 50W: 1m Flex
<b>Body colour:</b>	Black	<b>Input:</b>	220-240V, 50/60Hz
<b>IP Rating:</b>	IP66	<b>Electrical Classification:</b>	Class 1
<b>IK Rating:</b>	IK08	<b>Power Factor:</b>	>0.9
<b>Beam Angle:</b>	110°	<b>Protection:</b>	Overload / Short Circuit
<b>Adjustable Angle:</b>	0-180°	<b>Lifespan:</b>	>50,000hrs @Ta25°C (L70)
<b>CRI:</b>	>80	<b>Operating Ambient Temperature:</b>	-20 to 45°C
<b>SDCM:</b>	<5	<b>Dimming:</b>	Non-Dimmable

**APPLICATIONS**

Residential  
Schools  
Factories  
Public Areas

**ACCESSORIES**

**90° Corner Mount Bracket STAX90D-BRKT-S**  
(SAP 2002136)  
(Suits 20-50W models)



**PIR Sensor STAX-SENSOR**  
(SAP 2002135)  
(Suits 50W models only)



<b>Sensor Type:</b>	Passive Infrared
<b>Detection Angle:</b>	120°
<b>Detection Range:</b>	2 - 10m
<b>Time Setting:</b>	10sec - 7min
<b>Ambient Light:</b>	10 - 2000 Lux



STAX15W30W-TRI



STAX50W-TRI

**DIMENSIONS**

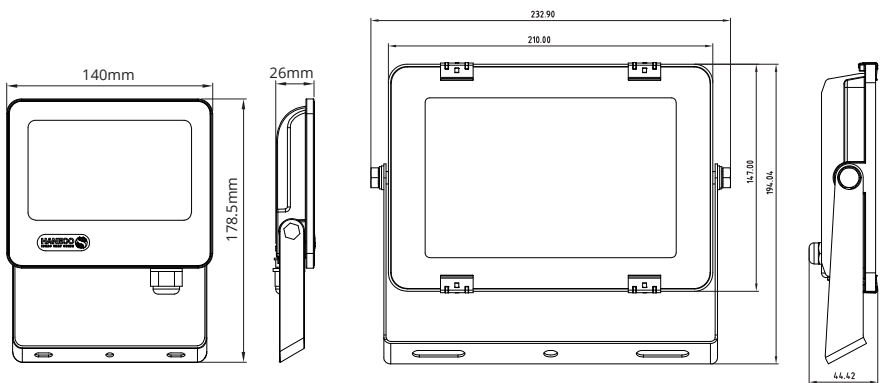

Outdoor Lighting

FIND OUT MORE:

